

ADDENDUM GROUP C:

Preliminary Information Packet
15 November 2006

**Addendum to Preliminary
Information Packet**
11 December 2006

Preliminary Information Packet: Adaptations of Cementitious Structural Insulated Panels (CSIPs) for Multi-Story Buildings

This document was prepared for the Industry Advisory Panel for the Charles Pankow Foundation award to the Federation of American Scientist. This award will allow FAS to study the adoption of Cementitious Structural Panels (CSIPs) in commercial construction including multi-story residential and commercial buildings.

This info packet provides professional engineers and architects preliminary background information regarding CSIPs. As an initial information packet to the professional community it includes a majority of information adapted from residential construction methods and only presents an initial snapshot on how CSIPs - as a technology - can be evaluated and integrated into commercial buildings.

November 15, 2006



Building Technologies
The FEDERATION of AMERICAN SCIENTISTS

Prepared by,
Joseph Hagerman, Program Manager
Zeynep Gueven, Research Associate

The Federation of American Scientists
1717 K St. NW suite 209
Washington, DC 20036

Table of Contents

Introduction to SIPs	2
General Evaluation Criteria of Building Products	7
Code Conformance	10
Acceptance Criteria for SIP Panels	14
Common Connection Details	17
Conclusion	21

Introduction to SIPs

What are SIPs? How do SIPs differ from CSIPs? What is the future of SIPs as a technology? What barriers are hindering larger SIP adoption?

Structural Insulated Panels (SIPs), as an underlying technology for Cementitious-Structural Insulated Panels (CSIPs), were developed over 50 years ago when the Forest Products Laboratory, established by the U.S. Department of Agriculture, built the first SIP house in 1935 in Madison, WI. This laboratory also built a SIP structure in 1947 which was tested and monitored for 31 years.¹ Following the laboratory's experiment, Alden B. Dow – son of the founder of DOW Chemical Company – designed SIPs for residential construction and built homes starting in 1952.

Even though SIPs have been on the market for a long time, currently they only make up approximately 2% of the residential construction market.² The Structural Insulated Panel Association (SIPA) was formed by a recommendation from HUD to SIP manufacturers to increase SIPs' market share. SIPA was formed through a partnership with the Engineered Wood Association (APA).

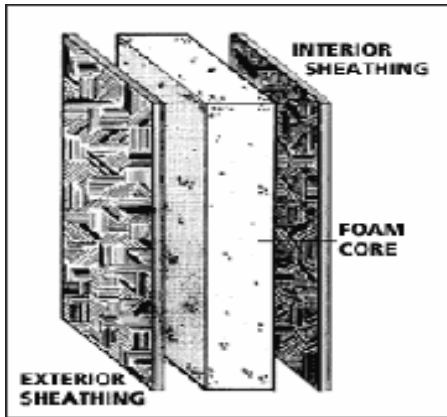

A common SIP is comprised of interior and exterior OSB sheathing with expanded polystyrene core in the middle. CSIPs replace the OSB sheathing with cementitious panel such as Hardieboard. *An OSB SIP with splines and top plate installed.*

Although SIPs have been slow to leave their mark on the construction industry, there is an increase in overall awareness of SIPs as a housing technology due to growing interest in energy-efficiency. SIPs are best known for their energy saving potential of 35-50% compared to traditional stick-built construction. Other advantages include environmental benefits from minimal on-site debris and rapid construction and better quality control. SIPs also offer excellent soundproofing properties, simplified construction, and versatility as the panels can be used in both load-bearing and non-structural applications. CSIPs offer these SIP advantages and have less reliance on wood and the price fluctuations in the wood industry.

SIPA, taking advantage of the growing interest in SIPs, has recently collaborated with the Partnership for Advanced Housing Technology (PATH) to “develop a set of prescriptive performance standards, which will be submitted for inclusion in the International Code Council's Residential Code (IRC).”³ SIPs inclusion in the building codes is likely to generate higher interest among builders; however, to date SIPA has been unable to get the technology accepted into the IRC. As a result, many manufacturers seek to get ICC-ES approval so local engineers and code officials can ensure that the manufacturers specifications conform to local building codes and standards. As a result, each SIP project must get an engineer's approval before being submitted for a building permit and the manufacture must supply the building department a copy of their ICC-ES report. This single regulatory barrier hampers larger SIP adoption.

Although SIPA's partnership with APA can be seen as a positive step for the industry, SIPs' close association with the wood industry may constrain the advancement of SIPs as an underlying technology and its long-term maturity into a more advanced building technology.

SIPs do not have to be limited by wood facings and can be made with metal or cementitious skins. Testing protocols developed by the APA indicate that SIPs are "just as good as" stick-built construction needed in order to get the product accepted as a replacement for stick frame construction. Ultimately, however, tying the performance of all SIPs to wood-faced SIPs may undermine the advanced properties that make SIPs a truly unique building product such as its excellent characteristic as a shear or diaphragm wall assembly. Currently, the industry imposes potentially unfounded safety factors to SIP's performance as a shear wall to lower its performance to that of braced stick framed construction. Although this may seem like a fair practice, SIPs are required to have straps and hold downs for high wind environments even though the performance of these connections have not been tested. Additionally, the ultimate strength of the SIP as a shear wall is more than twice of that required by even the strictest code, yet engineers cannot rely on this added strength because the ICC has discounted SIPs to 1/3 their ultimate shear strength. FAS is currently working on documenting the seismic characteristics of various SIPs to showcase their performance in earthquakes and to help advance their adoption to potentially address these aforementioned regulatory barriers.



CSIPs being erected during a residential construction.

Another potential misrepresentation of SIPs' advantages is caused by demonstration projects that have been very limited in scope. SIPs are typically demonstrated within the low income housing projects. Although this provides excellent press coverage for SIPs, it may devalue the technology by highlighting outsiders' frustration with SIPs, and does not secure national attention as these projects are often local in scope. These projects often use crews or volunteers who are uneducated about SIPs, making installation more confusing and frustrating than it needs to be. Although such demonstrations have not been ideal to showcase the versatility of SIPs, with the rebuilding of the Gulf, adoption of new codes addressing hurricanes and earthquakes, and the need to adopt fast, affordable and safe construction, the time is ripe to push SIP adoption on a national level – both in commercial and residential markets. To further increase SIP adoption, FAS sees great value in assembling a 'Builders' Guide to SIP Adoption' to facilitate the acceptance of SIPs by the construction industry – tailored to the builder's type (i.e. production vs custom homes) and size (ie. 6 units a year vs 600 units a year).

CSIPs have a competitive advantage over wood facings in harsh environments by offering increased durability to water. However, in order for CSIPs to become more aggressive competitors within the SIP industry – and to attract more manufacturers – the following durability requirements need to be identified regarding cementitious facings:

- Cost competitiveness with OSB,
- Lightweight (for easy on site construction),
- High impact resistance (to hinder jobsite damage),
- High abrasion resistance (to hinder the panel facings from getting “scuffed up”), and
- Improved ductility around corners and edges (to minimize the “chipping” of the edge).

Unfortunately the SIP industry has been lagging behind in research and development. As an organization, SIPA is only engaged in market and outreach, not research and development. The requirements listed above can be fulfilled with an innovative solution that can help chart an aggressive future for the panelized construction industry and particularly for the CSIPs. As with any wood based industry the manufacturers are confronting increased pressure to identify materials and solutions which contain a lower amount of organic content, are less reactive and more durable in the presence of water and have improved strength and durability at a lower cost. With increased costs and new market forces emerge, manufacturers are slowly demanding more options for facing materials.

Historically, SIPs have been manufactured to meet customer specifications (i.e. including door cut-outs), causing the overall cost and cost per square foot estimations to fluctuate. Even though cost is one of the most critical factors influencing construction industry’s decision on adopting SIPs, due to a large number of variables inherent to specific SIP projects, the SIP industry has had a hard time documenting costs and cost comparisons to stick built construction. Among the variables that influence the final cost are:

- architectural detailing;
- types of walls constructed with SIPs;
- types of roofs and roof systems;

- panel thickness; and
- performance criteria (i.e. snow load requirements, etc.)

Although it is difficult to run a cost comparison between SIPs and conventional stick-built construction due to aforementioned reasons, the overall consensus is that SIPs “cost about the same as building with wood frame construction, when labor savings resulting from shorter construction time and less job-site waste” are factored in.⁴ Since SIPs are composite structures with each component priced individually, the overall cost of the system often fluctuates; causing manufacturers to shy away from revealing their cost data. Despite the general reluctance to publish cost information, FAS found a CSIP manufacturer who was willing to share pricing information from February, 2006:

EPS-Core Size	Skin Thickness	Retail Price	+S,B,F,C. @ 25%	Retail Less 10%	+S,B,F,C @ 15%
3.75	7/16	3.88	4.85	3.49	4.01
5.75	7/16	4.26	5.33	3.83	4.40
7.50	7/16	4.59	5.74	4.13	4.75
9.50	7/16	4.97	6.21	4.47	5.14
11.50	7/16	5.35	6.69	4.81	5.53

*Stands for Splines, Braces, Fasteners, and Cuts

Cost data per sqft of panel, obtained from a CSIP producer based on February 2006 prices.

FAS is currently working to develop a Life Cycle Assessment (LCA) of SIPs and CSIPs, hopefully with the help of SIPA.

General Evaluation Criteria of Building Products

How do professionals evaluate building products? What life safety and performance criteria must we use to evaluate new technologies?

As a reference, Building Science Corporation’s ‘Builder’s Guide’ outlines an initial set of criteria that building product evaluations should be based on. There are a total of three

categories which must be considered: People Priorities, Building Priorities, and Environmental Priorities.

People Priorities:

- Health and Safety
 - Fire/smoke spread
 - Indoor air quality
 - Security
 - Structural
 - Accessibility
- Comfort
 - Temperature
 - Moisture (RH)
 - Odors
 - Sound/Vibrations
 - Light
 - Aesthetics
- Affordability
 - Capital Cost/Financing
 - Operating Costs from energy, water, maintenance
 - Life-cycle costs

While SIPs are known to fulfill most of the evaluation criteria defined above, there are areas where SIPs' superiority over stick-built may be inconclusive or lack substantiated third party data. For example, while many SIP producers have passed the 15 minute residential fire test under the auspices of UBC 26-3 rating, more vigorous fire codes for commercial or multi-family housing may oblige SIP manufacturers to design systems that can withstand hour-long tests. Even though fire testing in larger structures may require additional research, SIPs are expected to easily fulfill other health & safety criteria. As per comfort, temperature is not foreseen as an issue, as SIPs are known for their air-tightness. Soundproofing qualities of SIPs, as well as their versatility should also fulfill criteria regarding sound and aesthetics. Moisture performance in SIPs has been rather difficult to document as current moisture tests do not necessarily measure permeability or absorption rate effectively for SIP assemblies and connections. Another area where further research is necessary falls under 'Affordability'; while we know that SIPs are more energy-efficient than traditional stick-built homes, thus cheaper to operate in the long run, there is insufficient data on capital and life-cycle costs.

Building Priorities:

- Durability
 - Deterioration due to moisture

- Commissioning
- Operation/maintenance
- Expected service life
- Renewal, Reuse, Renovation
 - Future sub-system upgrades
 - Adaptability
- Decommissioning/disassembly
 - Benign materials
 - Disposable/recyclables

Durability evaluations under building priorities are derived from deterioration due to moisture; commissioning; operation/maintenance; and expected service to life. A more comprehensive life-cycle analysis is needed to determine SIPs' performance in the long run. Even though the insulation material found in SIPs is not recyclable, SIPs' reusability as a system offers great advantages.

Environmental Priorities:

- Local Environment
 - Construction waste
 - Operating waste
 - Construction water
 - Operating water
 - Rain water run-off/hydrology
 - Erosion of soil
- Regional Environment
 - Contamination of groundwater
 - Regional air pollution
 - Regional recycled materials/disposal
- Global Environment
 - Global warming
 - Biological diversity

'Environmental Priorities' are designed to evaluate a building's impact on the environment on local, regional, and global levels. As a building system that is mostly manufactured in a plant and that has excellent insulation properties, SIPs should easily meet local environmental standards outlined above. According to the SIPA website, "the Environmental Protection Agency (EPA) estimates that the average US home releases 22,000lbs of carbon dioxide into the atmosphere each year. That is twice the amount of average vehicle."⁵

The rise of energy efficiency awareness also helped leverage 'green construction,' which is a movement that aims to integrate sustainable components into construction in

order to help reduce buildings' impact on the environment during construction, as well as throughout a building's lifetime. According to the information found on the SIPA website, the most common "foam cores used in SIPs are made of mostly air and very little petroleum. The average SIP home saves nineteen times the energy it took to make the EPS insulation in the first year of installation."⁶

Code Conformance

What codes must panels conform to for residential and commercial construction? How are panels currently regulated?

Among the reasons that hinder the growth of SIPs is the lack of building codes that are tailored specifically for SIPs. In the absence of a better alternative, all SIPs must conform to the criteria designed for traditional stick-built houses as determined by the International Residential Code (IRC) and the International Code Council (ICC).

The following matrix was developed in order to document performance measures established for traditional construction in an effort to define basic guidelines for SIPs:

Fire				
International Residential Code (IRC)			International Code Council (ICC)- applicable under particular circumstances	
R302.1 R302.3	Flame Spread	R319.1- R319.3	Surface Burning, Sandwich Panel	3.4.1, 3.4.2 (reference to ASTM E 4)
	Fire Blocking, Wood Frame	R602.8- R602.8.1.2	Metal Skins AC214	
	Flame Spread, Insulation	R320.1- R320.5	Thermal Barrier Requirement, Sandwich Panel	3.5 (reference to IRC R318.1.2, R318.3, IBC 2603.5, 2603.7) 3.6 (reference to 2603.5, 2603.5.4)
	Foam Plastic, Surface Burning	R318.1.1	Metal Skins AC214	

Structure				
International Residential Code (IRC)			International Code Council (ICC)- applicable under particular circumstances	
R301.1 R301.2	Allowable Stress, Masonry	R606.4 R606.4.1	Traverse Load Test, Sandwich Panels AC04	4.3.1, 4.3.3 (reference to ASTM E 72, 4.3.4-4.3.10)
	Lateral & Vertical Support, Masonry	R606.8- R606.8.2	Axial Load Tests, Sandwich Panel AC04	4.4.1-4.4.6 (reference to ASTM E 72)
	Wind Load	R301.2.1, R301.2.2.2-design R301.2.1.3-exposure R301.2.2- R301.2.2.6-seismic	Thermal Barrier Requirement, Sandwich Panel Metal Skins AC214	3.5 (reference to IRC R318.1.2, R318.3, IBC 2603.5, 2603.7) 3.6 (reference to 2603.5, 2603.5.4)
	Snow	R301.2.3		

Vapor Retarders with Insulation				
International Residential Code (IRC)			International Code Council (ICC)- applicable under particular circumstances	
R322.1			Mold, Sandwich Panel Adhesives AC05 as required by AC04	8.8-8.8.2 (reference to ASTM D 905, ASTM C 297) 8.8.3 (reference to ASTM D 1623)
			Weather Protection, Sandwich Panel Metal Skins AC214	3.3 (reference to IRC R703.1 and IBC 1403)

E n e r g y C o m p l i a n c e			
International Residential Code (IRC)			International Code Council (ICC)- applicable under particular circumstances
N1101.2	Insulation	N1101.3.1	
N1101.2.1- Type A-1	Fenestration	N1101.3.2	
N1101.2.2- Type A-2	Thermal Performance	N1102.1	

D u r a b i l i t y C o n f o r m a n c e				
International Residential Code (IRC)			International Code Council (ICC)- applicable under particular circumstances	
	Decay (regional)	R323.1	Accelerated Aging, Sandwich Panel Adhesives AC05 as required by AC04	7.0-7.3 (reference to ASTM D 1183)
	Corrosion, Steel Framing	R603.2.3		
	Termite	R324.1, R324.3, R324.2		

O t h e r P e r f o r m a n c e			
International Residential Code (IRC)			International Code Council (ICC)- applicable under particular circumstances
	Acoustics	IBC 1207.1 -1207.3	
	Ventilation Outdoor	R303.1	

Performance specifications of SIPs as a system must conform to the code-regulated structural performance of the assembly and the durability performance of the parts. While SIPs need to meet a number of structural standards, three structural performance-requirements are critical to obtaining a certified panel:

- Transverse loading,
- Racking-sheer loading
- Axial loading – all performed according to ASTM E 72 standards.

The SIP industry determined a set of allowable design values derived from a combination of both the performance of facing materials and the performance measures established for general building products outlined above:

Table C2.3-2 - Allowable Design Values (plf) for SIP Wall Panels

Test Type	Panel Size	Panel Thickness	Test Method	Test Specifics	Mean Ultimate Load (plf)
Racking Shear	8- foot x 8-foot	4-1/2"	ASTM E72	ASTM E72 Monotonic, Section 14	981
	8- foot x 10-foot	4-1/2"			973
	8- foot x 8-foot	6-1/2"			943
	8- foot x 10-foot	6-1/2"			969
Axial Test	4- foot x 8-foot	4-1/2"	ASTM E72	ASTM E72 Section 9	10,857
	4- foot x 10-foot	4-1/2"			9,398
	4- foot x 8-foot	6-1/2"			9,650
	4- foot x 10-foot	6-1/2"			10,957
Transverse Test	4- foot x 8-foot	4-1/2"	ASTM E72	ASTM E72 Section 11	3,622
	4- foot x 10-foot	4-1/2"			3,278
	4- foot x 8-foot	6-1/2"			3,606
	4- foot x 10-foot	6-1/2"			3,442

Reference APA, The Engineered Wood Association Test Report No. T2006P-33.

Since the standard facing material used in the SIP industry is primarily Oriented-Strand-Board (OSB), design loads for CSIPs show slight variation due to the different properties of each facing material. As the table below suggests, CSIPs perform slightly better on Racking Shear and Axial tests, although there isn't enough evidence to assume that CSIPs surpass OSB SIPs in allowable Transverse design loads:

CSIPs						OSB SIP Results
Racking Shear*						
<i>Nominal Dimension</i>	<i>Ultimate Strength</i>	<i>FS</i>	<i>Allowable Load</i>	<i>% better</i>		<i>Allowable Load</i>
4.5"	988 plf	3	247 plf	5%		235 plf
12.5"	1046 plf	3	261 plf			
Axial Loading						
<i>Nominal Dimension</i>	<i>Ultimate Strength</i>	<i>FS</i>	<i>Allowable Load</i>			
4.5"	8887 plf	2.5	3555 plf	124%		1585 plf
12"	9403 plf	2.5	3761 plf			
Transverse Loading						
<i>Nominal Dimension</i>	<i>Ultimate Strength</i>	<i>FS</i>	<i>Allowable Load</i>			
4.5"	? psf	2.5	? psf	?%		50 psf

*Corrected from manufacturer's data

Acceptance Criteria for SIP Panels

What tests do the ICC require for SIPs?

Under the ICC AC04, the International Code Council compiled acceptance criteria for SIPs in order to “provide a procedure for recognition of sandwich panels in ICC Evaluation Service.”⁸ In addition to the principle tests described below in detail, the AC04 also feature information on connections, openings, etc.

The ICC defines three principle tests for sandwich panels: transverse load test, axial load test, and shear wall tests. Factor of safety (F.S.) as calculated by ICC are:

- F.S. = 2.0, ultimate load determined by bending failure for allowable live loads up to 20psf (958 Pa) and wind loads.
- F.S. = 2.5, ultimate load determined by bending failure for allowable snow loads.
- F.S. = 2.5, ultimate reaction at failure for all loading conditions.
- F.S. = 3.0, ultimate load at shear failure for all loading conditions.

Transverse Load Test: Transverse Load Test measures deflection when a load is applied perpendicular to the panel surface. For panels with brittle materials as facings, ICC requires that “with a 5-pound-per-square-foot (239Pa) horizontal loading imposed, the interior wall panel deflections shall not exceed” $L/240$ for use under the following code standards: Boca National Building Code (BNBC), State Building Code (SBC), Uniform Building Code (UBC), where ‘L’ is the length of the panel.

The ICC requires loads to be imposed in increments to failure, with deflections measured at each load. Deflection is monitored at “mid-span within 3 inches (76mm) of each edge and at the center of the panel’s width.” ICC criteria for transverse load tests call for “panels tested over a double span are to have the same three deflection readings taken at the expected maximum deflection point based on analysis.”

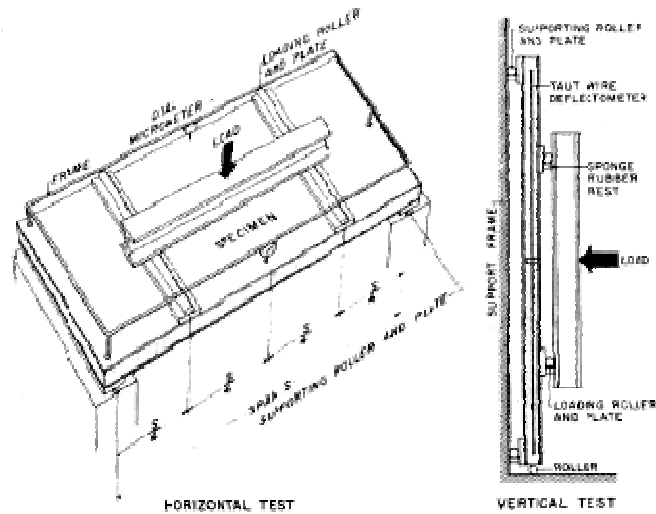
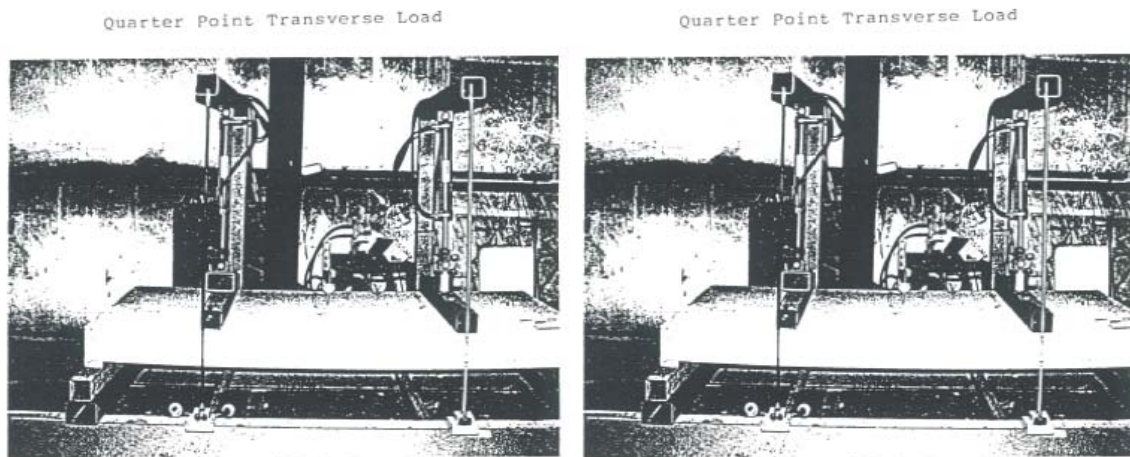

FIG. 3 Transverse Load Test on Wall Specimen

Transverse Load Test



Pictures depicting the actual test

Axial Load Test: Axial load tests are designed to determine panel's capacity to carry vertical loads from roofs, floors and walls and to lateral loads from wind forces. The ICC Acceptance Criteria for Sandwich Panels requires that: "load-bearing wall panels shall support an axial loading applied with an eccentricity of $1/6$ the panel thickness to the interior or towards the weaker facing material of an interior panel." ICC determines the allowable axial load by dividing the ultimate load (a load that when applied will result in failure) by a factor of safety (see below for more information on factors of safety).

Allowed loads can also be established by finding the load at which the axial deformation is at or below 0.125 inches (if this load is lower than the load obtained by dividing the ultimate load by a factor of safety).

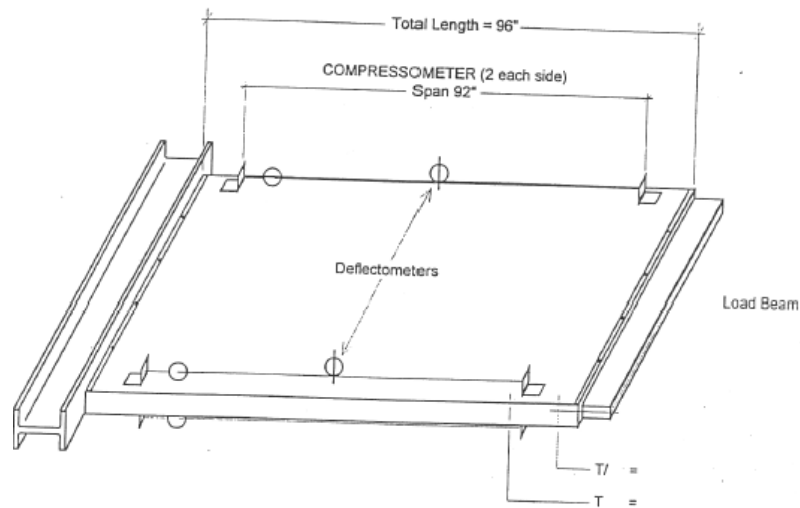

A diagram of the actual Axial Compressive Load test performed

According to ICC, the allowable axial load is determined by dividing the ultimate load by a factor of safety. Factors of Safety are explained above under the 'ICC Acceptance Criteria for Sandwich Panels.'

Wall Panel Racking Shear Test: Racking shear tests are required for shear walls that resist wind and seismic loads. According to the ICC Acceptance Criteria, the allowable shear load is determined from the racking load at which a net horizontal deflection of $\frac{1}{2}$ inch (12.7mm) occurs, or by dividing the ultimate load by a factor of safety as listed under the ICC Acceptance Criteria for Axial Wall Tests.

ASTM E 72 standards are designed to measure "the resistance of panels, having a standard wood frame, and sheathed with sheet materials such as structural insulating board, plywood, gypsum board, and so forth, to a racking load such as would be by winds." Performance of the sheathing is, therefore, defined as the test objective. Test set-up according to ASTM standards calls for the specimen to be attached to a timber or a steel plate. This plate is then attached firmly to the base of a loading frame in such a way that will not let racking to bear on the loading frame. A hold-down is also required to prevent the panel to rise as racking load is

applied, and since “the amount of tension in the rods of the hold-down may have an effect on the results of the test, nuts on the hold-down rods shall be tightened prior to load application so that the total force in each rod does not exceed 90 N at the beginning of the test as determined by previous calibration. Loading is then applied through the timber that is bolted to the upper plates of the specimen. Lateral guides and deflection measuring devices are required. Deflectometers should be located in the lower left (to measure any rotation of the panel), lower right (to measure any slippage), and upper right corners (the total of the two plus the deformation of the panel) of the assembly. Load is then applied continuously.

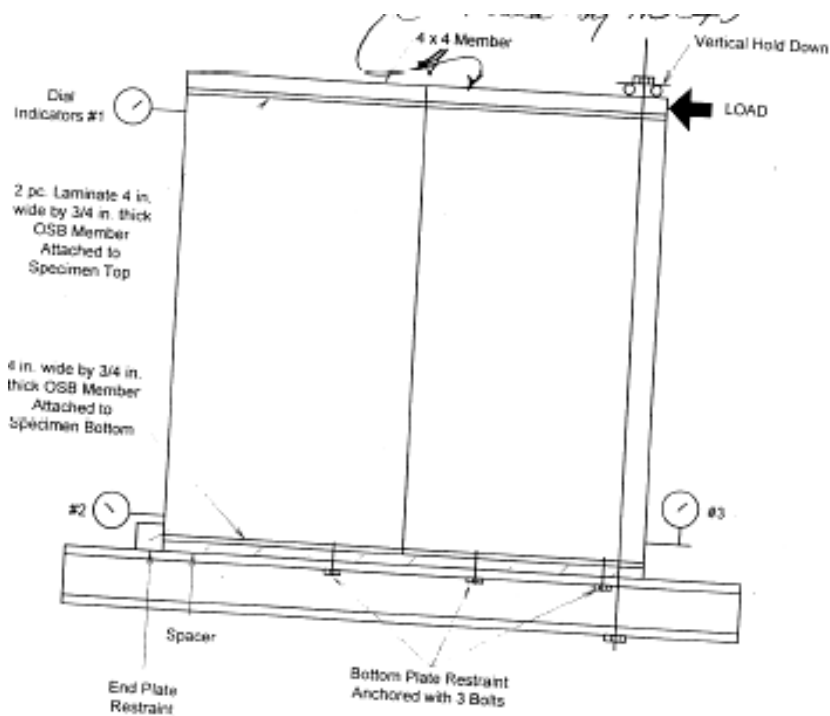

The Racking Shear test performed

Common Connection Details

What is the standard practice for connections within the SIP industry? What connections may be applicable to commercial construction?

Although CSIPs and SIPs with OSB facings tend to follow similar connection details for residential construction, through its research, FAS has identified a number of manufacturers who use different techniques for connections. Among these, two systems

have attracted FAS' attention due to their applicability to multi-story structures: Home Front Homes in Florida, and ProTec Panels by Finpan. Manufacturers of Home Front Homes utilize CSIPs as curtain walls by using a simple steel frame for structural support:



Home Front Homes – Ridge Beam Installation



Home Front Homes – Interior of Finished Shell

Producers of ProTec, on the other hand utilize C-channels and metal track to connect panels as a structural wall assembly. Additionally, they use metal splines between the panels. One unique feature of the ProTec System is that the splines are made within the insulation core and not at the facing material. Although this connection detail may require a more substantial engineered connection, the added material between the facing material and the void of the connection (approximately 1" of extruded polystyrene) will insure less damage during handling and transport.

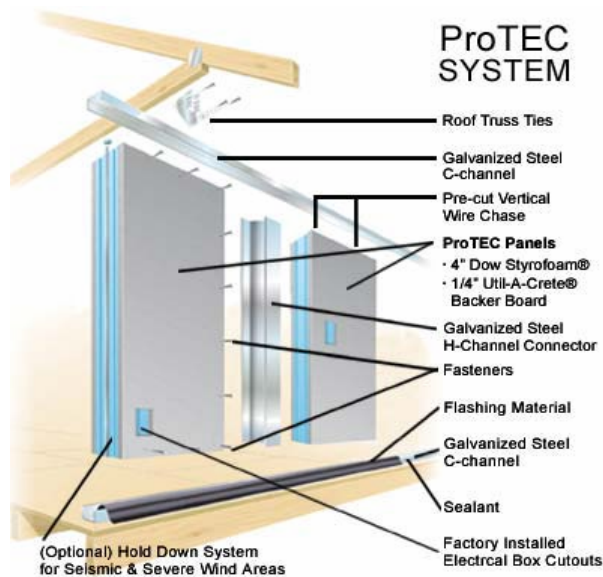

ProTec Panels

The structural properties of SIPs are fully exploited in residential construction, where connections tend to be less complicated. Examples of common residential SIP connections used particularly in OSB SIP industry are demonstrated below:

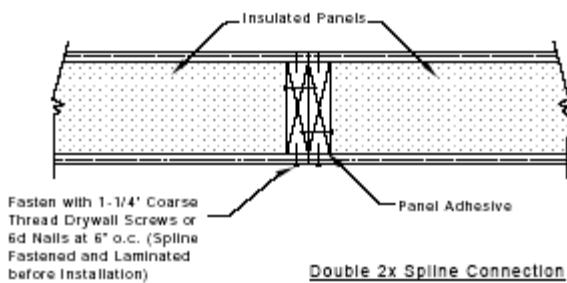

General Panel Corp. – Double 2x Spline Connection (plan)

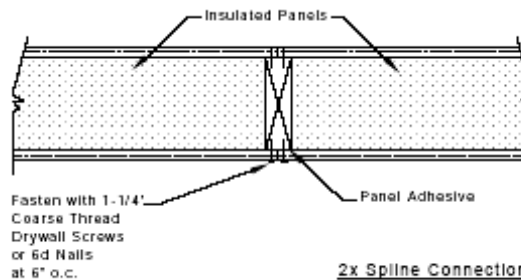

General Panel Corp. – Single 2x Spline Connection (plan)

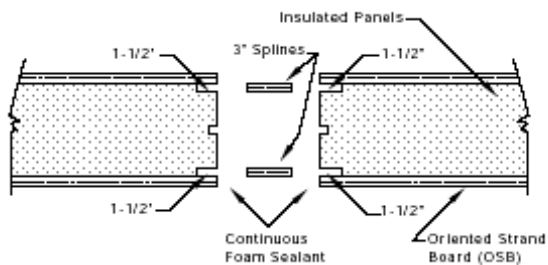

General Panel Corp. – Section Panel Detail 1 (plan)

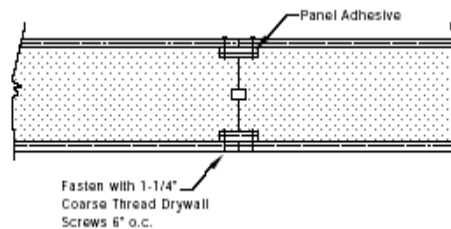

General Panel Corp. – Section Panel Detail 2 (plan)

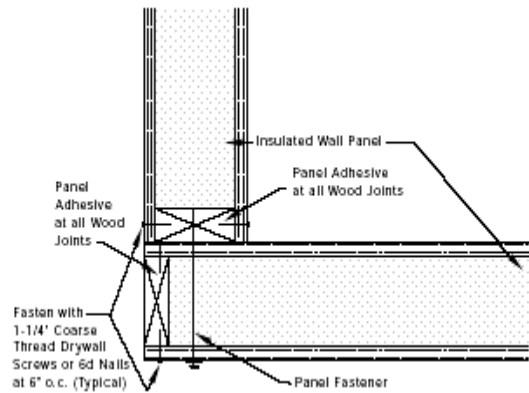

General Panel Corp – Wall Panel Corner Connection (plan)

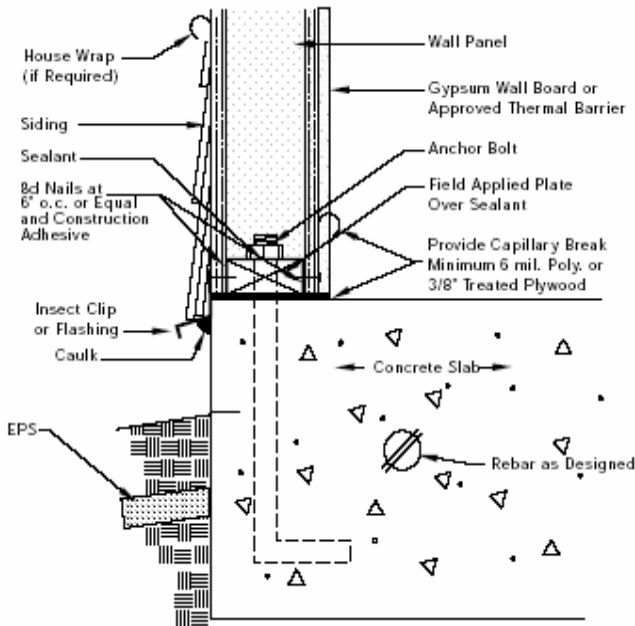

General Panel Corp – Wall/Slab Connection

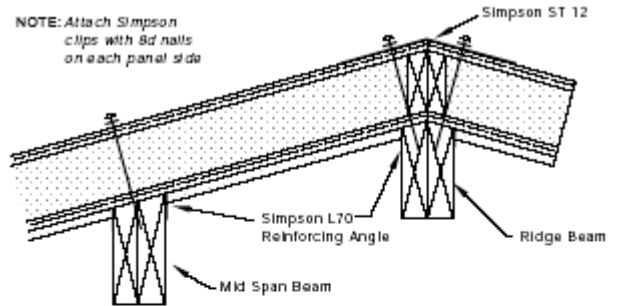

NOTE: Attach Simpson clips with 8d nails on each panel side

NOTE: Install all reinforcing metal at panel edges and/or 4' o.c.

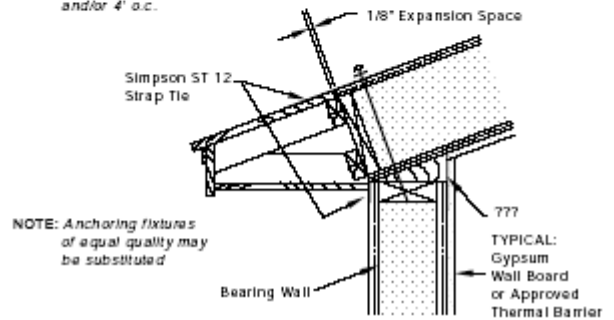

NOTE: Anchoring fixtures of equal quality may be substituted

Ridge/Purlin Connections & Built-out Eave Soffit

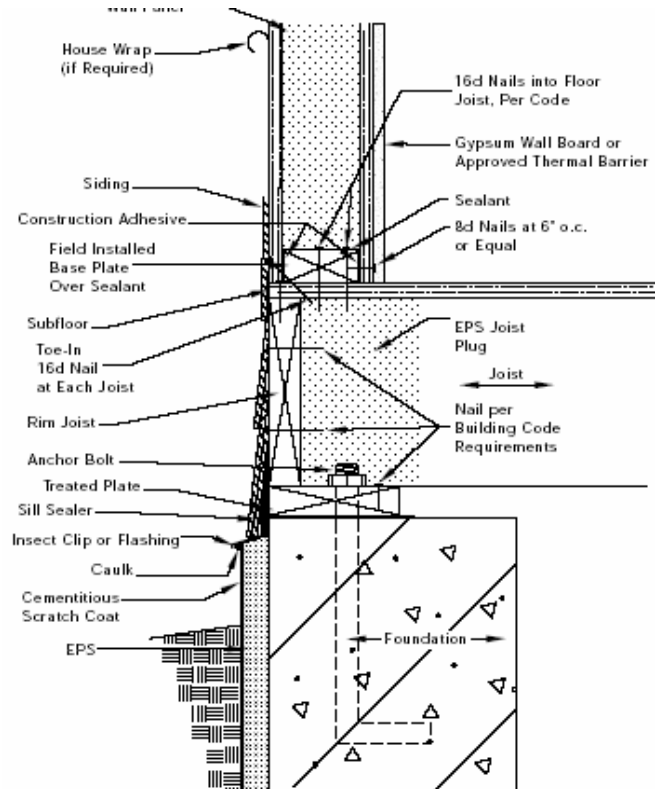

General Panel Corp – Wall over Floor at Foundation

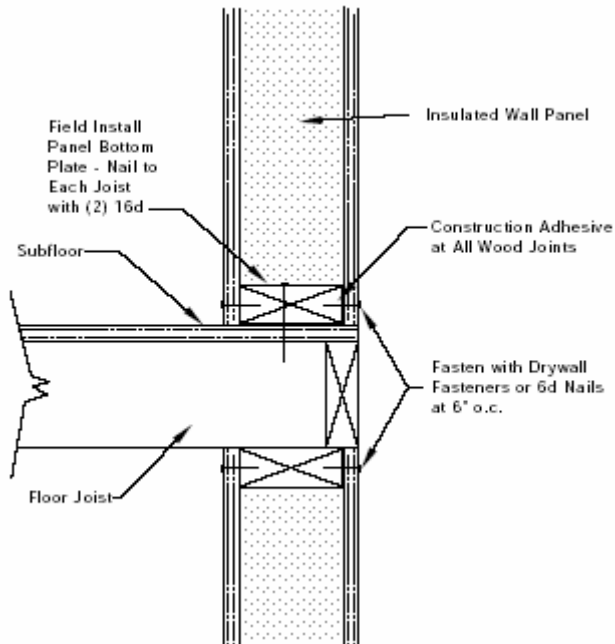

General Panel Corp – Second Floor Wall Connection

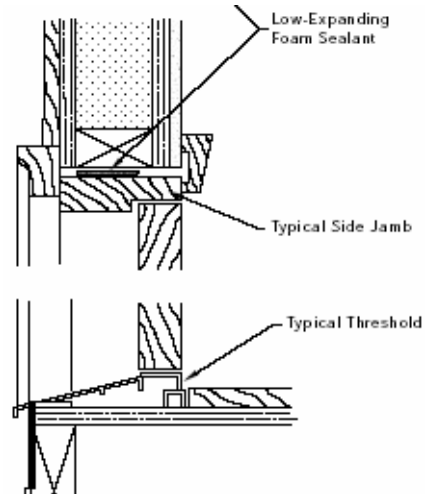

General Panel Corp – Threshold Details

Conclusion

FAS feels that the Pankow Foundation Award will help the SIP industry, particularly the CSIP industry, to potentially chart a more aggressive future into the building market. This ultimately falls on developing a tool to help professionals get educated on SIPs as a technology and provide them with the information and resources they need to design structures with SIPs so that buildings can realize the SIP advantages of increased energy efficiency, structural strength, and ease of construction at potentially a lower cost.

Our opportunity involves:

- Documenting the strength and structural advantages of SIPs/CSIPs and report the performance of panelized system to the professional community;
- Educating builders, manufacturers, and professionals of each other's needs to improve constructability and durability;
- Optimizing CSIPs as a panelized system and its details for commercial construction.

End Notes

¹ Get Energy Smart.org “What Are SIPs?” <<http://www.getenergysmart.org/Files/Presentations/HY-R%20NYSERDA%20Presentation.ppt>> 8 Nov. 2006

² E-Build: The Professional’s Guide to Building Products, “Construction Products Overview: Structural Insulated Panels,” <<http://www.ebuild.com/guide/resources/product-news.asp?ID=353470&catCode=15>> 8 Nov. 2006

³ Get Energy Smart.org “What Are SIPs?” <<http://www.getenergysmart.org/Files/Presentations/HY-R%20NYSERDA%20Presentation.ppt>> 8 Nov. 2006

⁴ Structural Insulated Panel Association, “What are SIPs?” <http://www.sips.org/portal/tabid_3898/Default.aspx> 8 Nov. 2006

⁵ Structural Insulated Panel Association, “SIPs are Green,” <http://www.sips.org/portal/mid_16429/ModelID_0/PageID_12/tabid_7122/Default.aspx> 9 Nov. 2006

⁶ Structural Insulated Panel Association, “SIPs are Green,” <http://www.sips.org/portal/mid_16429/ModelID_0/PageID_12/tabid_7122/Default.aspx> 9 Nov. 2006

⁸ ICC Evaluation Service, Inc., “Acceptance Criteria for Sandwich Panels: AC04”, February 2004

Addendum to “Preliminary Information Packet”

Adaptations of Cementitious Structural Insulated Panels (CSIPs) for Multi-Story Buildings

This document was prepared by the Federation of American Scientists as an addendum to “Preliminary Information Packet” presented to the Industry Advisory Panel for the Charles Pankow Foundation award.

This addendum provides information on the history and evolution of SIPs; discusses general evaluation criteria of building products, compares CSIPs with regular SIPs and describes connection details and acceptance criteria for SIPs based on structural ICC tests. This addendum was produced per the Industry Advisory Panel’s request to further assess the market potential of CSIPs.

December 11, 2006

Building Technologies
The FEDERATION of AMERICAN SCIENTISTS

Prepared by,
Joseph Hagerman, Program Manager
Zeynep Gueven, Research Associate

The Federation of American Scientists
1717 K St. NW suite 209
Washington, DC 20036

Addendum to “Preliminary Information Packet: Adaptations of Cementitious Structural Insulated Panels (CSIPs) for Multi-Story Buildings”

December 11, 2006

Contents

Contents	2
Abstract.....	2
About the Federation of American Scientists	3
Cost & Savings Potential	4
Costs.....	5
Benefits	6
Preliminary Issues.....	6
Corrections.....	7
Conclusion	9

Abstract

This document outlines information on the history and evolution of SIPs; discusses general evaluation criteria of building products, compares CSIPs with regular SIPs and describes connection details and acceptance criteria for SIPs based on structural ICC tests. Although SIPs were first developed in 1930s, their transition to mainstream construction market has been painstakingly slow. The SIP industry’s dominance by wood facings (OSB), the lack of well-organized demonstration and outreach projects, the difficulty in obtaining credible cost data and the lack of literature on the regulation and performance of SIPs are among reasons that impede adoption of SIPs on a greater scale.

Although the research done to date on SIPs is limited to residential construction and wood facings, the SIP industry established a set of design values based on the performance of facing materials, which are modeled after general building performance measures. The SIP industry has calculated mean ultimate loads to determine allowable design values. According to the values established for SIP Wall Panels, the mean allowable racking shear load is 327plf (on an 8 ft x 8 ft panel, 4 ½” thickness); mean allowable axial load is 4342plf (on a 4 ft x 8 ft panel ½” thick); the transverse mean allowable load is 50psf (on 4 ft x 8 ft panel, 4 ½” thick). While the design values determined by the SIP industry provided technical information on panels, it excluded SIPs with alternative facings, such as fiber-cement board.

Initial structural tests performed on CSIPs, though incomplete, suggest that SIPs with fiber-cement board facings perform slightly better on Racking Shear than SIPs with wood facings, with a mean allowable load of 339plf (8 ft x 8 ft CSIP, 4 ½” thick). There is, however, a lack of conclusive evidence to suggest that CSIPs surpass OSB SIPs on Axial and Transverse loading tests (See the table under *Corrections*). All tests were performed on panels with connections residential in nature (i.e. using dimensional wood).

As the worldwide demand for multi-story construction is growing rapidly, FAS will evaluate a variety of design options for CSIP integration including their structural strength, energy efficiency, earthquake and hurricane resistance, and costs. The principle project goal is to select a preferred design and deliver a complete design, ready to be employed on actual CSIP construction projects, for the rapid adoption by the building construction industry and its customers.

About the Federation of American Scientists

The Federation of American Scientists (FAS) was formed in 1945 by atomic scientists from the Manhattan Project. Endorsed by nearly 60 Nobel Laureates in chemistry, economics, medicine, and physics as sponsors, the Federation has addressed a broad spectrum of national security issues of the nuclear age in carrying out its mission to promote humanitarian use of science and technology.

Today, the Federation continues its 60-year exemplary record of achieving meaningful results in strategic security, with research and education projects in nuclear arms control and global security; conventional arms transfers; proliferation of weapons of mass destruction; information technology for human health; and government information policy.

FAS has expanded the policy activities to address our country’s critical challenges in housing, energy and education. The Building Technologies Project at the Federation of American Scientists is working to advance innovation in building design and construction that can improve quality, affordability, energy efficiency and hazard protection while lowering construction and operating costs. Technical advances, including new composite materials and prefabricated components, can help meet these goals in ways that are beneficial to both builders and owners. While the construction industry does not yet seem receptive to alternative building methods, the lack of research in critical areas poses another barrier to the wide adoption of Structural Insulated

Panels (SIPs) as a composite material. FAS seeks to address this problem by evaluating, disseminating and supporting advanced building materials, technologies and systems. FAS has assembled an interdisciplinary team of experts many of whom have had years of experience in the construction industry to develop lasting close links with the industry to ensure that the results of the research will transfer immediately into commercial practice.

Cost & Savings Potential

Cost and savings potential are not easily addressed by applying what little data is available for residential construction to commercial construction. Also, common residential connection details, mostly adapted from wood stud construction, may not be allowed in commercial construction. It is unknown what costs are associated with recertifying panels for alternative connections at this point.

However, a preliminary discussion follows first by presenting in comparison, CSIPs, OSB SIPs (which dominate the SIP marketplace), and standard residential construction (using both wood and steel studs). Following this, we discuss the potential benefits of the CSIPs which address the value added to the system.

Costs

	Wood Framed Walls	Steel Stud Framed Walls	Wood Faced OSB SIPs	Cementitious Faced SIPs	
Material description (interior face to exterior face)	Dimensional 2x4 framing, 16" (2x4) or 24" (2x6) O.C., #2 or better studs, exterior sheathing for structural support, interior insulation in cavity, gypsum board interior, double top plate, Tyvek house wrap, exterior finishing per drawings	Dimensional 2x4 18 gauge steel stud on track, exterior sheathing for structural support, interior insulation in cavity, gypsum board interior, double top plate, Tyvek house wrap, exterior finishing per drawings	Gypsum, Wood faced SIP, house wrap, exterior finishing per drawings	CSIP, applied exterior finish is required	
Technical Description	Sheathing nailed typically at 3" edge, 6" field nails, using #10 nails, sheathing shall be structural grade (7/16"), double top plate for structural walls	Sheathing screwed at 3" edge, 6" field nails, using #8 screws, sheathing shall be structural grade (7/16")	Glued at top and bottom plate, #10 nails Laminated splines are fastened with 1 1/4" coarse thread drywall screws or 6d nails at 6" on center	Glued at top and bottom plate, #8 drywall screws, Panels are connected to each other using splines of 7/16" fiber cement board using 1 1/4" #6 screws with 6" on center. Plates are attached with 2" coarse thread screws with 6" on center spacing	
Material Cost Breakdown	Finished Material Cost per Square Foot of Wall Area				
	Materials	2x4	Steel Stud	Wood SIP	CSIP
	Interior Finish	\$0.25	\$0.25	\$0.25	1 labor unit
	Structural Members	\$0.15	\$0.05		
	Insulation	\$0.10	\$0.10		
	Sheating	\$0.35	\$0.35	\$2.35	
	Housewrap	\$0.05	\$0.05	\$0.05	\$3.90
	Exterior Finish	\$0.70	\$0.70	\$0.70	1 labor unit
	Labor Units	x 6 units	x 6 units	x 4 units	x 3 units
	Total (excluding Labor)	\$1.60	\$1.50	\$3.35	\$3.90

Although the cost per square foot estimates shown above demonstrate a considerable difference between the cost of traditional practices and SIPs, it is important to factor in savings potentials such as reduced labor, shortened construction time, and long-term energy and durability savings to due excellent insulation properties and CSIPs' resistance to mold and termites in certain regions.

Benefits: (wood walls, steel stud walls, CSIP, WSIP)

	Wood Framed Walls	Steel Stud Framed Walls	Wood Faced OSB SIPs	Cementitious Faced SIPs
Advantages	Mature, adopted technology in residential construction, covered by prescriptive codes, no regulatory barriers, low cost	Lighter weight when panelized, mature, adopted technology in commercial construction, covered in prescriptive code, no regulatory barriers, low cost	Increased strength, increase energy efficiency, large wall panels are possible (i.e. 8x24), shortened construction duration, no need for skilled labor (panel installation is relatively easy), manufacturers are widespread in the US	Increased durability and energy efficiency; shortened construction duration, little or no wood, resistant to termites and mold, little or no need for skilled labor
Dis-advantages	OVE framing not widespread, a lot of wood used as a result, labor intensive, uses highly skilled/trained labor, poor energy performance, quality of materials and construction standards is rapidly decreasing, difficult to find commercial applications	OVE framing not widespread, a lot of steel used, labor intensive, uses highly skilled/trained labor, poor energy performance, difficult to find residential applications	Connections are residential in scope, heavily reliant on wood; price fluctuations as a result; application limited to structures under 3 stories, costly; must finish interior and exterior sides of panels for durability/fire protection	Application so far limited to structures under 3 stories high, dimensions of panels limited by cement board; brittle in transportation and constructability; few manufacturers, lack of sound structural data to date

Preliminary Issues (facing CSIP migration from Residential to Commercial construction):

- a. Connections are typically wood (and may not meet commercial code's combustibility requirements) and prolonged fire resistance required in commercial construction for the facing material (may require alternate facing materials);
- b. Weight is substantially greater than competitive wood and steel stud systems (this concern may not be an issue in commercial construction);
- c. Constructability and transport results in damaged products because CSIPs are brittle as compared to other SIP products (this problem may be minimized with connection detail changes);
- d. Residential construction is interested in providing combined structure and wall assembly where commercial construction is typically post and frame construction with curtain wall panels (thereby reducing the loads that the panels will receive);
- e. Lack of building codes that are designed for SIP/CSIP construction and a general lack of architectural and professional buy in;

- f. Lack of a fiber-cement board that is optimized for construction, limitations on panel size (may result in adopting a magnesium oxide board which is growing in popularity); and
- g. Lack of data on life cycle analysis & durability.

Corrections

FAS has an interest in providing the industry with the best possible data on CSIP performance. We have yet to verify the CSIP tests but are looking to do so in early January as we test alternative connection details. After reviewing the initial information provided by the manufacturer we believe that some structural values have been over-reported and we are eager to correct the data to ensure we deliver the professional community the best quality information. We hereby submit a correction to the Shear Values as posted in the original report, however there won't be any values listed for Axial and Transverse capacity due to the data being inconclusive.

Per Shear Values, it is important to consider the modes of failure determined by ICC AC04 and ASTM E 72 testing protocol. The four Racking/Shear failure modes for panels are: the most obvious failure occurs if the assembly physically fails with a Factor of Safety (FS) of 3.0 (1). The second mode of failure is governed by how much the assembly deflects; an assembly is considered to be failed if it deflects more than 0.5 inches with an FS of 3.0 (2). A third failure mode depends on whether the allowable shear load of fasteners is less than that of the assembly with an FS of 1.0 (3). Finally, if hold-downs are used on the assembly, the allowable deflection may not exceed 0.125 inches with an FS of 3.0 (4). Based on the failure modes determined by the ICC and ASTM protocols, we compiled the following chart to illustrate ultimate loads recorded at each mode:

	TEST #1	TEST #2	TEST #3
Mode of Failure:			
1	14,645 lbs per assembly	9,105 lbs per assembly	11915 lbs per assembly
2	~10,500 lbs per assembly	Assembly Did Not Fail	~7,000 lbs per assembly
3°	Unknown	Unknown	Unknown
4¹	Not Recorded (but less than 7,895 lbs per assembly)	2,435 lbs per assembly	2,995 lbs per assembly
° Failure Mode 3 will not be verified until the Fortified Tests are performed in December.			
¹ After reviewing images of the assembly, it is our opinion that Failure 4 is the governing failure.			

Per ICC AC04, allowable loads for the mean of each failure mode are calculated by dividing the Mean Ultimate Load by the corresponding Factor of Safety:

	Mean Ultimate Load (lbs per assembly)	Mean Ultimate Load (plf)	Factor of Safety	Mean Allowable Load (plf)
Mode of Failure:				
1	11,858 lbs per assembly	1482plf	3.0	494plf
2	8,750 lbs per assembly	1094plf	3.0	364plf
3	n/a	n/a	1.0	n/a
4	2,714 lbs per assembly	339plf	1.0	339plf

According to the ICC, the lowest value obtained from different modes of failure determines the design value, represented by the fourth failure mode that corresponds to a mean allowable load of 339plf – which is slightly higher than the Shear value of OSB SIPs at 327plf.

Conclusion

While the growing interest in alternative building methods and more energy-efficient structures presents a great opportunity for the SIP industry, it also highlights the need for compiling presentable data on key issues such as performance specifications and cost information. FAS is interested in performing fundamental structural tests especially after reviewing test results that were either over-reported or inconclusive. Our reassessment of structural tests shows that while even the readjusted numbers for Racking/Shear tests outperform wood SIPs, independent testing of Transverse and Axial loading may be necessary to fully comprehend panels' performance characteristics.

FAS also appreciates the importance of providing the construction industry with reliable cost data. Unfortunately, it is very difficult to obtain cost information from SIP manufacturers, as current estimates on cost per square foot of different construction methods register higher costs for SIPs and CSIPs. Even though the cost saving potential of SIPs is very hard to document, educating the industry about potential savings from reduced labor, shortened construction time, long-term energy and durability savings should be an integral part of the execution of the Pankow Foundation Award.